

EN 15266 PLUG & RUN

NO ELBOW, NO WELD

EASY & SAFE INSTALLATION
WITH UNIQUE QUICK COUPLING DESIGN

New generation flexible
installation system broke the
mould of the natural gas
installation.



Handbook

kas.com.tr | [f](https://www.facebook.com/kasgrup) [i](https://www.instagram.com/kasgrup) [t](https://www.twitter.com/kasgrup) /kasgrup

KASTAK[®]
new generation natural gas installation



KAS-TAK USAGE AND FEATURES OF NEW GENERATION INSTALLATION SYSTEM

KAS-TAK offers high-safety, advantageous and brand new option for you as a new generation installation system that provides gas transmission to natural gas-operated devices in houses such as boilers, stoves, cookers starting from the natural gas counter flexes and can also be used outdoors within an extra protective sheath or plastic pipe.

KAS-TAK, is earthquake-resistant, easy to install, flexible, consists of stainless steel hose and apparatus.

Practical and easy montage speeds up your work, allowing you to install more plumbing during the day. Thanks to the practicality of the installation phase, pollution and damage are minimized in installation areas.



"4 TIMES FASTER INSTALLATION"



KAS-TAK

Technical Specifications

KAS-TAK hoses are manufactured from stainless steel sheet material according to EN 10028-7, with high precision and quality workmanship. It is covered with protective cover against external effects and is shipped on a metric basis.

ADVANTAGES OF KAS-TAK SYSTEM

- **KAS-TAK** system does not require welding, sheet, grind cutting, linen and putty.
- Montage of the **KAS-TAK** system is practical and easy.
- The twistability and flexibility of the **KAS-TAK** system eliminates the need for an elbow.
- **KAS-TAK** system takes up little space, is lightweight, easy to transport and minimizes transportation costs.
- **KAS-TAK** system does not cause wall contamination or visual disturbance.
- In the **KAS-TAK** system, the installation hoses are placed inside the ducts, creating an aesthetic appearance.
- **KAS-TAK** system is resistant to both wear and corrosion thanks to its stainless steel hose and outer sheath.
- **KAS-TAK** system has been being used safely in Japan and the USA for over 25 years





KAS-TAK Sample Piping System Chart

- **Gas:** Natural gas, LPG
- **Product Max Working Pressure:** Less than or equal to 500 mbar (0.5 bar).
- **KAS-TAK Flex Implementation Area Pressure:** If the implementation is to be used in residential or domestic appliances (boiler, stove, hot water heater, etc.), the gas pressure after the meter can be made for installations up to 21 mbar.

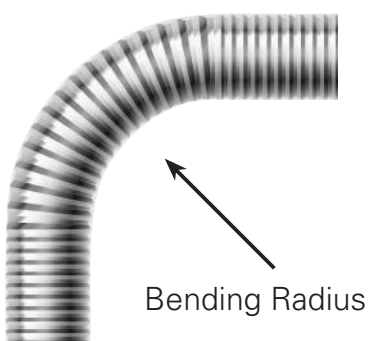

KAS-TAK Hose Bending Radius

Min Bending Radius (mm)		
DN 16	DN 20	DN 25
20	25	30

KAS-TAK is a system produced in accordance with the European Standard EN 15266.

RECOMMENDATIONS FOR USERS

PRELIMINARY REMARK:

The proposals made to the user are to prevent accidents, gas leakages and similar accidents. Please take these recommendations into account in order to avoid serious accidents and damages.

1. The **KAS-TAK** installation must be installed by installers who have successfully completed the training program and have license to install the natural gas piping and/or equipment.
2. Only parts supplied or recommended by **KAS** should be used in the installation.
3. **KAS-TAK** products are not compatible with other manufacturers' systems. If you use **KAS-TAK** products with other manufacturers' products, you may encounter unexpected problems.
4. In **KAS-TAK** installation, usage brochure and local construction rules must be strictly observed.
5. Our company will not accept any liability for misunderstanding or complying with any information contained in the use brochure, whether in accordance with local natural gas indoor installation or engineering specifications.
6. While **KAS-TAK** installation offers important advantages to users and implementers, depending on the situation, to avoid being affected by adverse events such as damaged by any object, lightning strike or electrical load, the implementer must be sure that the system is installed correctly.
7. It should not be used in areas with temperatures above 60 °C
8. It should not be used on the main column side of the gas meter
9. It should not be used in areas where piping or plastic piping can not be fixed
10. Corrosive (bleach, lime, etc.) environments for stainless steels should not be used in areas such as bathrooms, toilets, etc.
11. **KAS-TAK** hoses must be laid in the **KAS-TAK** ducts where the wall is already fixed. The ducts should be fixed at a maximum spacing of 75 cm.
12. The diameter of the corrugated pipe should not be changed by addition and/or reduction. Until TEE-separation, the installation should be one piece, at TEE-separation should be made diameter change with reduction.
13. Clamp mounting should be done to fix the used natural gas valves.
14. It is recommended that the wall passes be made through the sheath.



15. Pipe bends should not have angled bends of less than 90°.
16. In all other structures except for individual structures (buildings with an independent unit number of 1), the corrugated pipe must not pass through the atmosphere (from the exterior of the building) area (except the balcony, terrace).
17. The “TEE” material should not be exposed outside the premises, such as on balconies, terraces, or in places where there is a switchover from the exterior of detached buildings.
18. After the meter, the line should enter the residence from the shortest distance. However, in mandatory situations the application of corrugated pipe in the stairwell and / or through the shaft can only be done with the approval of the gas distribution company.
19. In the case of using corrugated pipes in the installation after the meter, steel or copper pipes can not be used in the same installation.
20. In the application of flexible hose, additional materials such as linen, natural gas putty, teflon, liquid seal etc. are not used during fitting of the fasteners.
21. Make sure the electrical grounding of the complete piping is done appropriately. Grounding procedure **MUST** be performed by a certificated electrician and in accordance with EN 15266 or country-based other standard.
22. Nut & ring assembly is for single-use only. In case of incorrect assembly or manufacturing, please change this part with a new “**KAS** nut & ring assembly kit”.
23. Do NOT step on the hose. Do NOT hammer the hose.
24. Tighten the fittings by **ONLY** turning the nuts. Fix the fitting body with the help of another wrench etc. Do not twist the hose by turning it during tightening
25. Make sure that the hills/corrugations of the hose are intact and **NOT** deformed during the cutting process by overloading on the hose via the cutting apparatus
26. Tighten the fittings until the end while **NO** thread can be seen.



Mounting Instructions

HOSE CONNECTION FITTING MOUNTING INSTRUCTION



Hose connection fitting parts



Mounted hose connection fitting parts



The hose should only be cut 360 degrees using the cutting apparatus. It should not be torn off by hand. Cut stone etc. should not be used.



Cutting the hose by apparatus and undressing the outer coating. Can the coating be undressed first, then the cutting shall also be performed.

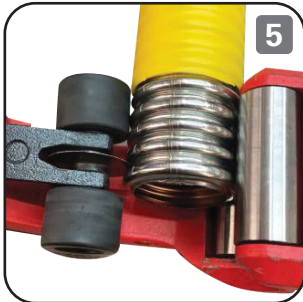

If possible, please use a cutting tool with rubber roller guides. Make sure that the guide rollers are not pressing on the hose corrugations.

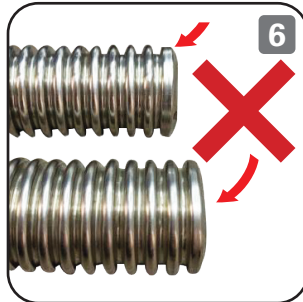

Be sure that, the hill of the corrugation is not flattened / deformed during cutting procedure. If the corrugation is deformed, the functionality of the brass ring will be hindered.

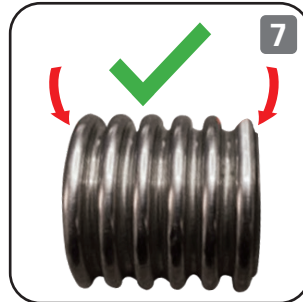

Corrugation at the cutting zone is intact. No deformation occurred.

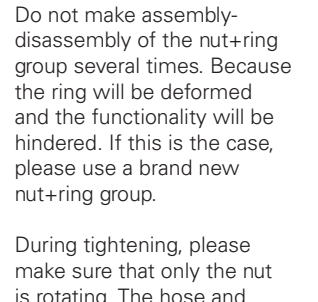

Do not make assembly-disassembly of the nut+ring group several times. Because the ring will be deformed and the functionality will be hindered. If this is the case, please use a brand new nut+ring group.

During tightening, please make sure that only the nut is rotating. The hose and the fitting's body should not rotate. If so, this will hinder the functionality of the sealing mechanism.



After 5 waves / corrugations are undressed



Crushed, incorrectly cut product



Not properly cut product

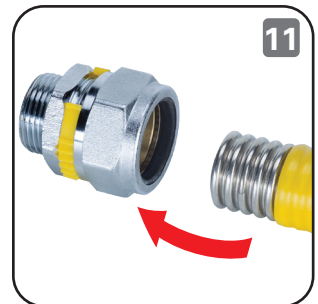

Connection form of hose to connection fitting. **Important note:** Be sure to hear the "click" sound when mounting by hand.



After the click sound, remove the limiter PVC clamp

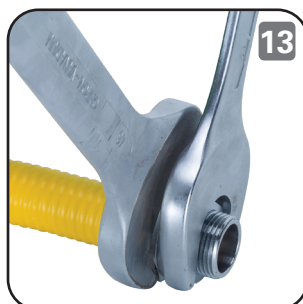

Mounting with dual wrench



Incorrect Mounting

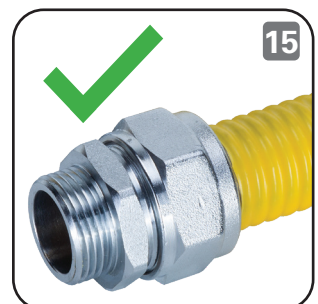

Correct Mounting

Perform the assembly of the hose with the fittings, while the nuts and safety clips are on. If the assembly is performed while they are not on, it can cause the brass ring in the nut to catch more number of waves than necessary and/or the rubber sealing may fall off unknowingly. Both will hinder the functionality.

TEE CONNECTION FITTINGS MOUNTING INSTRUCTIONS

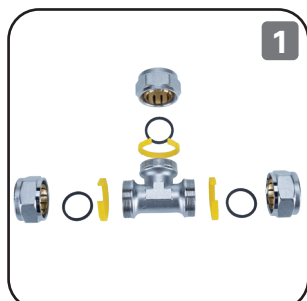

TEE hose connection fitting parts



TEE mounted hose connection fitting parts

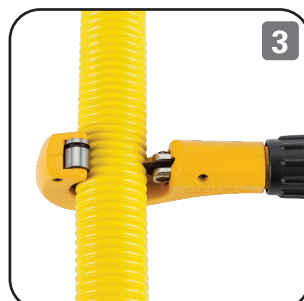

The hose should only be cut 360 degrees using the cutting apparatus. It should not be torn off by hand. Cut stone etc. should not be used.



Elimination of flexible hose coating by apparatus

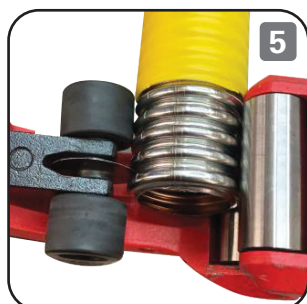

If possible, please use a cutting tool with rubber roller guides. Make sure that the guide rollers are not pressing on the hose corrugations.

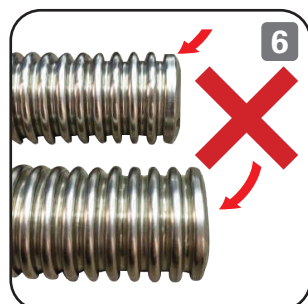

Be sure that, the hill of the corrugation is not flattened / deformed during cutting procedure. If the corrugation is deformed, the functionality of the brass ring will be hindered.

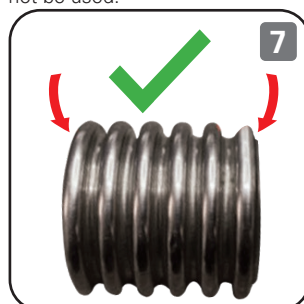

Corrugation at the cutting zone is intact. No deformation occurred.

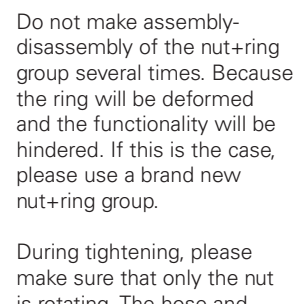

Do not make assembly-disassembly of the nut+ring group several times. Because the ring will be deformed and the functionality will be hindered. If this is the case, please use a brand new nut+ring group.

During tightening, please make sure that only the nut is rotating. The hose and the fitting's body should not rotate. If so, this will hinder the functionality of the sealing mechanism.



After 5 waves / corrugations are undressed



Crushed, incorrectly cut product



Not properly cut product

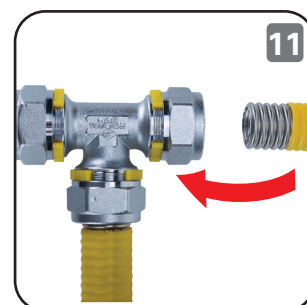

Connection form of hose to connection fitting. **Important note:** Be sure to hear the "click" sound when mounting by hand.

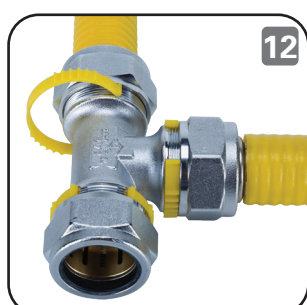

After the click sound, remove the limiter PVC clamp



Mounting with dual wrench



Incorrect Mounting



Correct Mounting

Perform the assembly of the hose with the fittings, while the nuts and safety clips are on. If the assembly is performed while they are not on, it can cause the brass ring in the nut to catch more number of waves than necessary and/or the rubber sealing may fall off unknowingly. Both will hinder the functionality.



▶ KAS-TAK GAS CONNECTION SYSTEM



▶ *KAS-TAK Gas Appliances*

CODE	INSTRUCTIONS
65.30.016	DN 16 Internal Installation Hose (45 mt)
65.30.020	DN 20 Internal Installation Hose (30 mt)
65.30.025	DN 25 Internal Installation Hose (25 mt)
65.30.050	DN 25 Internal Installation Hose (50 mt)
65.32.020	DN 32 Internal Installation Hose (20 mt)
65.32.050	DN 32 Internal Installation Hose (50 mt)



▶ *Double Sealing Technology*

CODE	INSTRUCTIONS
60.16.012	DN 16 x 1/2" Hose Connection Fittings
60.16.016	DN 16 x 3/4" Hose Connection Fittings
60.20.012	DN 20 x 1/2" Hose Connection Fittings
60.20.016	DN 20 x 3/4" Hose Connection Fittings
60.25.012-2	DN 25 x 1/2" Hose Connection Fittings
60.25.016-2	DN 25 x 3/4" Hose Connection Fittings
60.25.025-2	DN 25 x 1" Hose Connection Fittings
60.32.025	DN 32 x 1" Hose Connection Fittings
60.32.032	DN 32 x 1" 1/4" Hose Connection Fittings



► **TEE Connection Union**

CODE	INSTRUCTIONS
61.20.020-2	DN25xDN20xDN20 T-Connection Fittings
61.20.021-2	DN20xDN25xDN20 T-Connection Fittings
61.20.025-2	DN25xDN20xDN25 T-Connection Fittings
61.25.020-2	DN25xDN25xDN20 T-Connection Fittings
61.25.025-2	DN25xDN25xDN25 T-Connection Fittings
61.32.2525-2	DN32xDN25xDN25 T-Connection Fittings
61.32.2532-2	DN32xDN25xDN32 T-Connection Fittings
61.32.3225-2	DN32xDN32xDN25 T-Connection Fittings
61.32.3232	DN32xDN32xDN32 T-Connection Fittings



► **Metal-Metal Quick Coupling Union with Purging Valve**

CODE	INSTRUCTIONS	
60.20.125	DN 20 - 3/4"	1
60.25.117-2	DN 25 - 1" External Threaded Solenoid Connection	2
60.25.118-2	DN 25 - 1" Internal Gear	3
60.25.125-2	DN 25 - 1 1/4" Casting Gland	4
60.25.126-2	DN 25 - 1 1/4" With Gland	5
60.32.126	DN 32 - 1 1/4" With Test Purifier	6



► KAS-TAK GAS CONNECTION SYSTEM

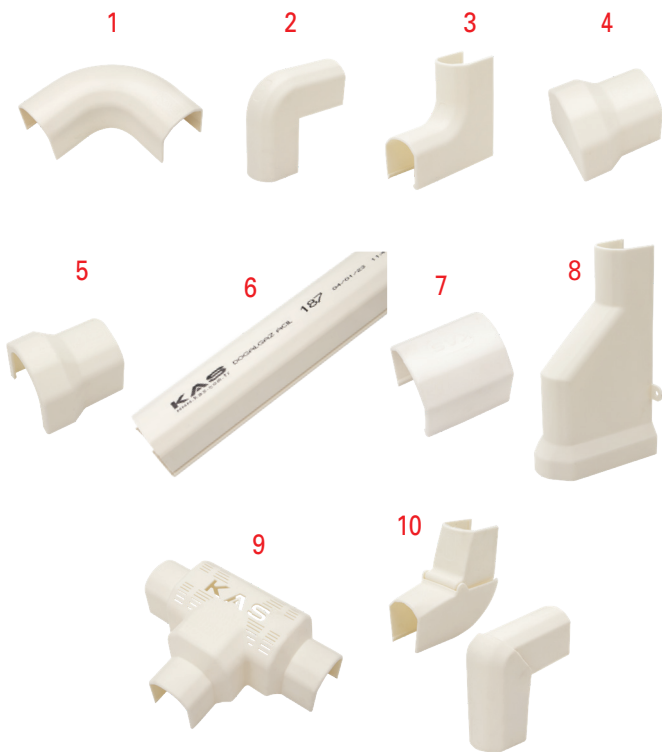

► *Trunking and Accesories for Flexible Hoses - White*

CODE	INSTRUCTIONS	
63.22.003	L Corner	1
63.22.004	Outside Corner	2
63.22.005	Inside Corner	3
63.22.006	Wall Pass Cover (Closed)	4
63.22.007	Wall Pass Cover (Open)	5
63.34.002	Hose Duct 2 mt	6
63.22.010	Channel Transition Cover	7
63.22.015	Meter Shutdown	8
63.22.016	TE Closure	9
63.22.017	Angled External Corner	10
63.22.018	Angled Inside Corner	



► **Clamp for Gas Appliances**

CODE	INSTRUCTIONS	
60.04.011	1/2" Valve Clamp	1
60.04.012	3/4" Valve Clamp	1
60.04.020	DN 20 T Clamp	
60.04.025	DN 25 T Clamp	2
60.04.032	DN 32 T Clamp	
60.05.020	DN 20 Hose Connection	3
60.05.025	DN 25 Hose Connection	



► **Mounting Tools**

CODE	INSTRUCTIONS
49.51.001	Flex Hose Cutting Apparatus
63.01.009	TEE Tightening Apparatus Interior Installation

**YOUR HOME
DESERVES
BEING
CLEAN AND
UNDAMAGED**



EN 15266

KAS[®]



KASTAK
new generation natural gas installation

kas.com.tr | [f](#) [t](#) [i](#) [g](#) /kasgrup

*Eyüp Sultan Mahallesi
Mezarlık Yolu Sokak No: 4
Sancaktepe/Istanbul-TURKEY
Tel: +90 216 311 35 45
Fax: +90 216 311 29 61*

[f /kastak.tesisat](#) [t /kastak_tesisat](#)